

THE

# Howston

1 bed + den

660 square feet  
unit 03-04 reverse

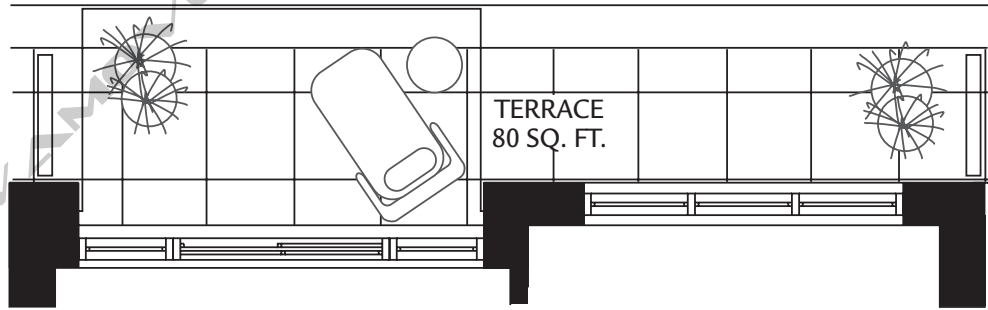

2ND FLOOR

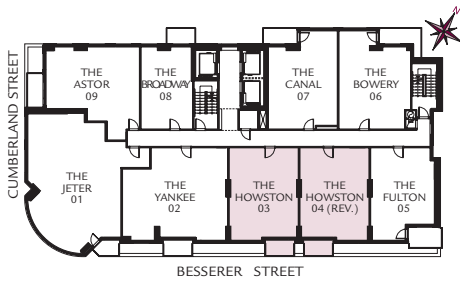
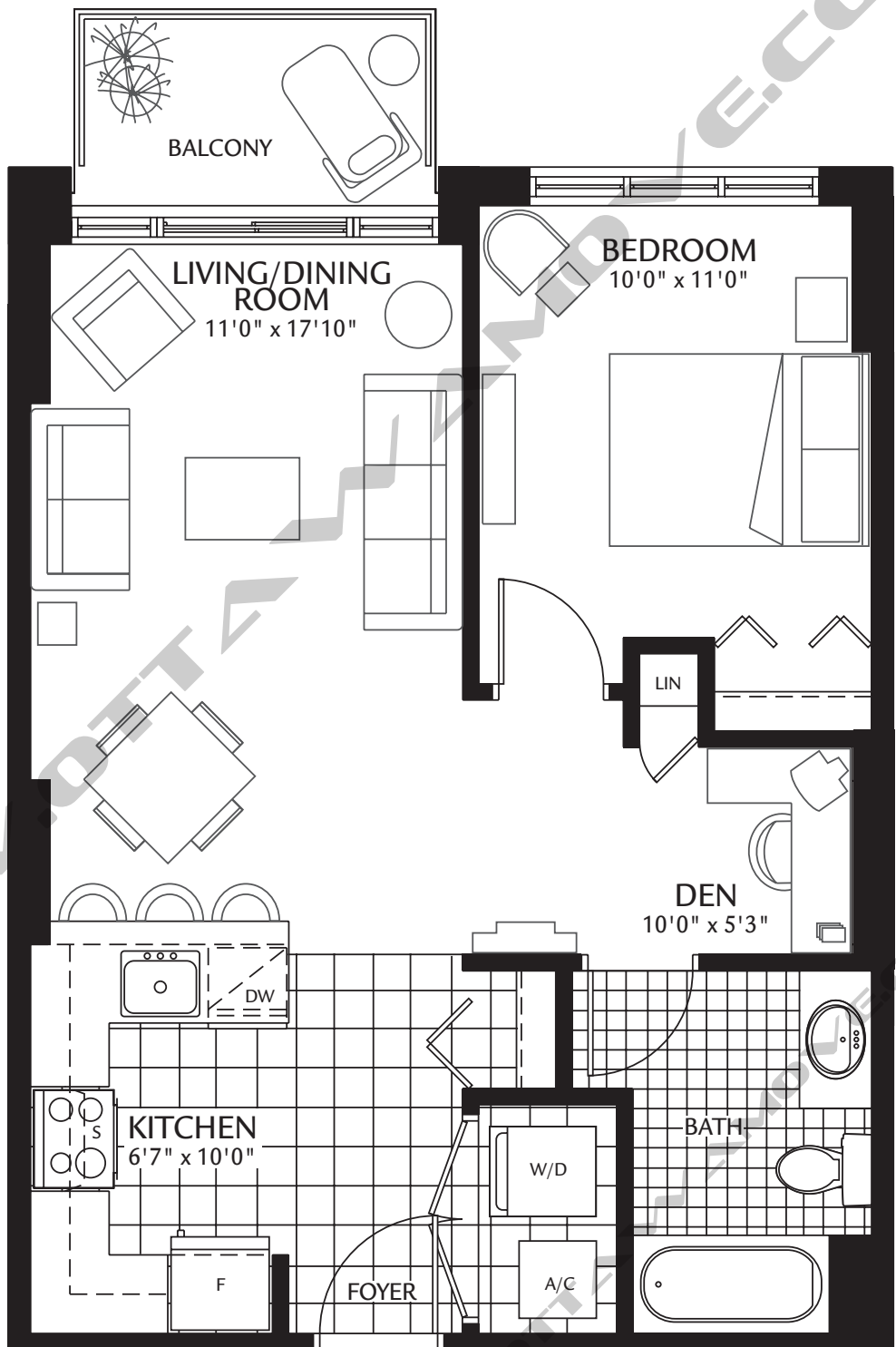

2ND - 26TH FLOORS



CLARIDGE  
PLAZA



Plans and specifications are subject to change without notice. Bulkheads and dropped ceilings will be added as required for mechanical, electrical and structural elements. Actual usable floor space may vary from the stated floor area. E. & O.E.